

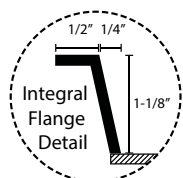

# UST-ALRC01SNW

ALCOVE BATHTUB WITH SKIRT

Shown right drain version

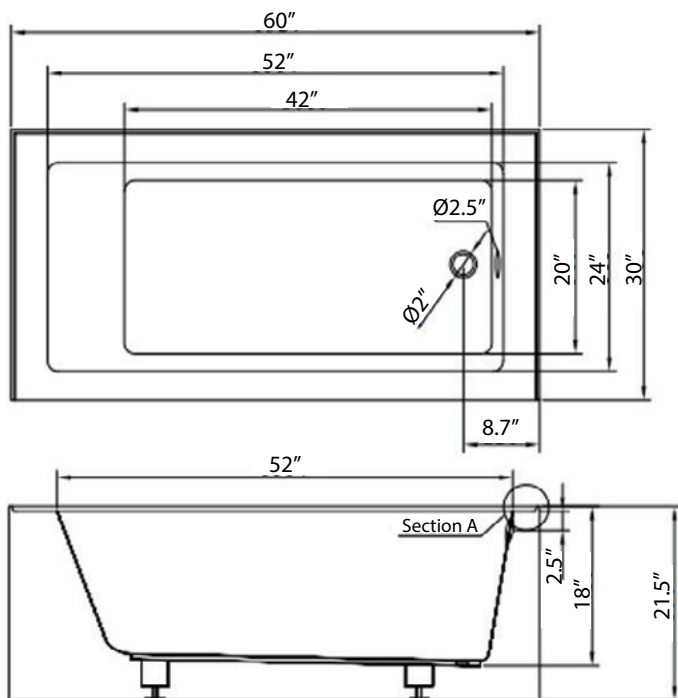

## Style:

- Alcove Tub
- Skirted
- Linear Raised Outlet

## Materials:

- Acrylic
- Fiberglass
- Resin

## Size:

- Overall: 60" x 30" x 21.5"

## Features:

- \*(L)Left and (R)Right Drain Versions Available
- Reinforced integral skirt
- Built-In Tile Flange
- Lumbar Support
- maximum support.
- High gloss acrylic surface for a bright shine.
- Covered with a protective film to maintain finish during installation.
- Easy to clean. Stain resistant.
- Easy to install for both new construction and remodel projects.

## Capacity To Overflow:

- 61 gallons

## Warranty:

- Lifetime Limited Warranty

## Available Color/Finish



## Models Available:

- UST-ALRC01SNW

